

## All Harrod UK 5-A-Side Football Goals conform to the BS 8462:2005 Standard.

### Important Note:

All freestanding goals **MUST** be anchored at **ALL** times. Harrod UK recommend that two ground anchors must be applied to all freestanding football goals to conform to the applicable BS EN 748:2004 or BS 8462:2005 standard.

**It is essential to conduct a risk assessment of your particular site to evaluate the suitability of specific types of anchorage.**

Please see ground anchor instruction number INS535 for available anchors.

**Use of Counterbalance weights** - Counterbalance weights are an effective method of stabilising goal posts, but care should be taken to ensure the correct amount of weight is used:

✂ 5-A-Side Freestanding Football Goals need 105kg of weight (6 x ANC-005)

PLEASE READ ALL OF THE INSTRUCTIONS FOR YOUR GOAL BEFORE YOU BEGIN ASSEMBLY.

### Greasing

To increase the life of your goal you should grease all crossbar joints and moving parts.

Waterproof instructions are available on request

### FS1 Foldaway Steel Goal (Patent No GB9502230.7).

Portable, Folding free-standing, with mitred crossbar joints. Made from 50.8mm diameter steel with 25.4mm diameter net supports.

### Assembly

If a net is to be fitted, it is a good idea to thread the crossbar through the net before assembly.

Each person should hold one sideframe and one end of the crossbar. The crossbar can then be lowered onto the sideframe until the button clip engages in one of the two holes.

The Back Bar should now be inserted into the collar on the back of each side frame. Depress the button clip to engage into the hole in the collar.

**Please Note:** Initial assembly may require some force to fit the side frame into the crossbar. This is normal and is necessary so that when the paint wears off internally over time from folding, the stability of the goal is not compromised.

### Operation

To fold the goal, simply depress the button clip and fold the sideframe until the button clip locates in the other hole.

**Do not lift the crossbar when the button clip is disengaged from one of the two holes** - this is not necessary and may cause the crossbar to lift off the sideframe and the goal to collapse.

### Important

**Do not try to fold the goal when the button clips are engaged.** This could break the clips and damage the frame.

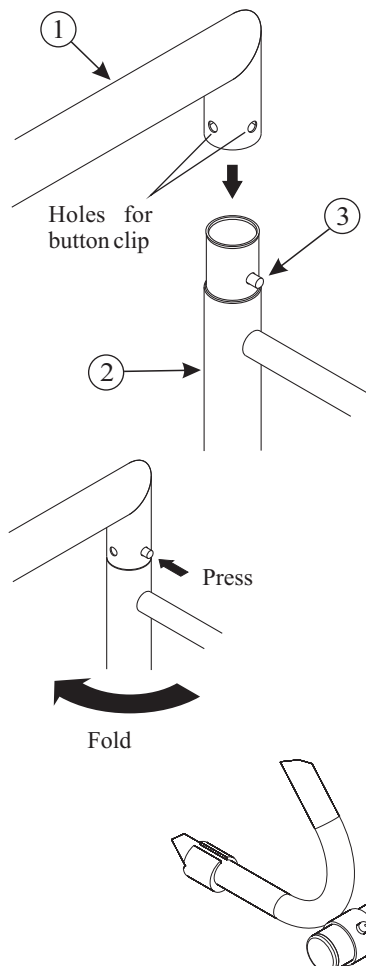

### FBL-036 4.88x1.2m Components

1. 1 x Crossbar (pair). (FEQ200)
2. 1 x Sideframe (set of 4). (FEQ203)
3. 4 x Button Clip (pre-fitted). (SPE107)
4. 1 x Back Bar (pair). (FEP625)

### FBL-037 3.66x1.2m Components

1. 1 x Crossbar (pair). (FEQ201)
2. 1 x Sideframe (set of 4). (FEQ203)
3. 4 x Button Clip (pre-fitted). (SPE107)
4. 1 x Back Bar (pair). (FEP626)

### FBL-038 2.44x1.2m Components

1. 1 x Crossbar (pair). (FEQ202)
2. 1 x Sideframe (set of 4). (FEQ203)
3. 4 x Button Clip (pre-fitted). (SPE107)
4. 1 x Backbar (pair). (FEP627)

### Assembly Requirements

Number of People: 2  
Time to Assemble: 3 minutes  
Tools Needed: None

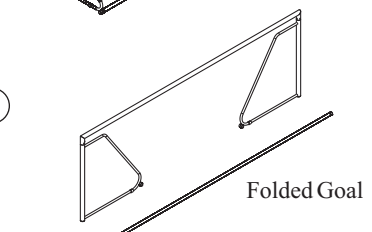
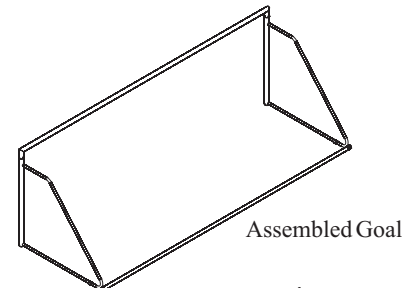

Code:

Product: 5-Aside Steel Football Goals

### FS5 Socketed Steel Goal.

Made from 50.8mm diameter heavy steel with 31.8mm diameter fully welded sideframes with sockets.

#### Assembly

Prepare the ground so that you have a trench approx 516mm deep, 1566 long and wide enough at each end to pour a 476mm cube of concrete. Position the sockets in the trench and pack so that the top of the socket is level with the finished ground level. To ensure an accurate positioning of the sockets assemble and sit the goal in the sockets before pouring the concrete (If the goal is not available to do this then use the upright centres given below).

Always use a spirit level on the uprights and crossbar to ensure that the goal is installed true. Allow at least 24 hours for the concrete to set before use.

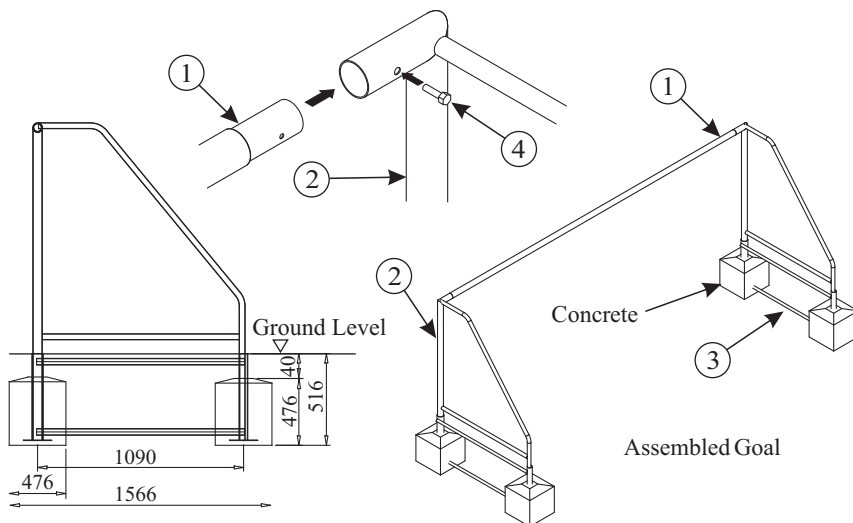

#### FBL-131 4.88x1.2m Components

1. 1 x Crossbar (pair). (FEQ228)
2. 2 x Sideframe (pair). (FEQ223)
3. 2 x Socket (pair). (FEQ224)
4. 4 x M8 Bolt (pre-fitted). (BOL530)

#### FBL-132 3.66x1.2m Components

1. 1 x Crossbar (pair). (FEQ229)
2. 2 x Sideframe (pair). (FEQ223)
3. 2 x Socket (pair). (FEQ224)
4. 4 x M8 Bolt (pre-fitted). (BOL530)

#### FBL-133 2.44x1.2m Components

1. 1 x Crossbar (pair). (FEQ230)
2. 2 x Sideframe (pair). (FEQ223)
3. 2 x Socket (pair). (FEQ224)
4. 4 x M8 Bolt (pre-fitted). (BOL530)

#### Assembly Requirements

Number of People: 2  
Time to Assemble: 2 hours  
Tools Needed: 1xSpade  
Concrete Mixer  
Spirit Level

#### Upright Centre

FBL-131 4931mm Centres  
FBL-132 3714mm Centres  
FBL-133 2490mm Centres

### FS6 Permanent Steel Goal.

Made from 50.8mm diameter heavy duty steel with 31.8mm diameter fully welded sideframes which are cemented into the ground.

#### Assembly

Prepare the ground so that you have a trench approx 516mm deep, 1558 long and wide enough at each end to pour a 476mm cube of concrete. Assemble the goal, position it in the trench and pack so that the underside of the crossbar measures 1.22m from finished ground level.

Using a spirit level on the uprights and crossbar, ensure that the goal is installed true and then pour the concrete. Allow at least 24 hours for the concrete to set before use.

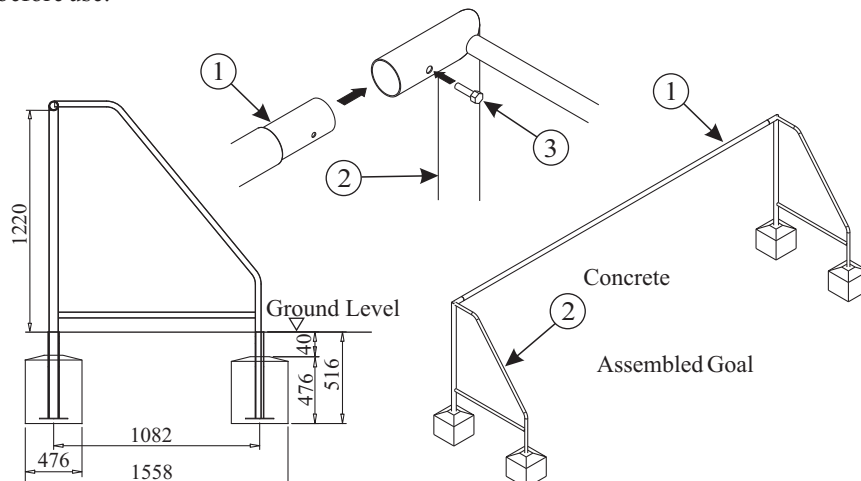

#### FBL-134 4.88x1.2m Components

1. 1 x Crossbar (pair). (FEQ228)
2. 2 x Sideframe (pair). (FEQ226)
3. 4 x M8 Bolt (pre-fitted). (BOL530)

#### FBL-135 3.66x1.2m Components

1. 1 x Crossbar (pair). (FEQ229)
2. 2 x Sideframe (pair). (FEQ226)
3. 4 x M8 Bolt (pre-fitted). (BOL530)

#### FBL-136 2.44x1.2m Components

1. 1 x Crossbar (pair). (FEQ230)
2. 2 x Sideframe (pair). (FEQ226)
3. 4 x M8 Bolt (pre-fitted). (BOL530)

#### Assembly Requirements

Number of People: 2  
Time to Assemble: 2 hours  
Tools Needed: 1xSpade  
Concrete Mixer  
Spirit Level

#### Upright Centre

FBL-134 4931mm Centres  
FBL-135 3714mm Centres  
FBL-136 2490mm Centres

**Code:**

**Product:** 5-Aside Steel Football Goals

### **FS8 Folding Wheel-Away Steel Goal.**

Made from 50.8mm diameter heavy duty steel with 31.8mm diameter folding sideframes and flip-over wheels.

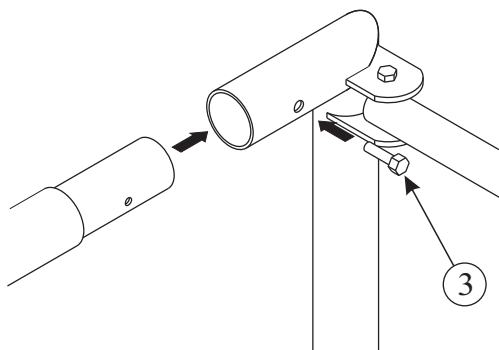

#### **Assembly**

Remove the pre-fitted bolts from the crossbar. If a net is to be fitted, it is a good idea to thread the crossbar through the net before assembly.

Each person should hold one sideframe and one end of the crossbar. Insert the ends of the crossbar into a sideframe elbow and secure with the bolts.

If the Back Bar has been supplied in 2 halves; join together as shown below, by depressing the button clip and insert the smaller tube into the open end.

The Back Bar should now be inserted into the collar on the back of each side frame. Depress the button clip to engage into the hole in the collar.

#### **FBL-125 4.88x1.2m Components**

1. 1 x Crossbar (*pair*). (FEQ228)
2. 2 x Sideframe (*pair*). (FEQ100)
3. 4 x M8 Bolt (*pre-fitted*). (BOL530)
4. 1 x Backbars (*pair*). (FEP752)

#### **FBL-126 3.66x1.2m Components**

1. 1 x Crossbar (*pair*). (FEQ229)
2. 2 x Sideframe (*pair*). (FEQ100)
3. 4 x M8 Bolt (*pre-fitted*). (BOL530)
4. 1 x Backbars (*pair*). (FEP753)

#### **FBL-127 2.44x1.2m Components**

1. 1 x Crossbar (*pair*). (FEQ230)
2. 2 x Sideframe (*pair*). (FEQ100)
3. 4 x M8 Bolt (*pre-fitted*). (BOL530)
4. 1 x Backbars (*pair*). (FEP754)

#### **Assembly Requirements**

Number of People: 2  
Time to Assemble: 5 minutes  
Tools Needed: 1x13mm Spanner

2-Part Back Bar (if applicable)

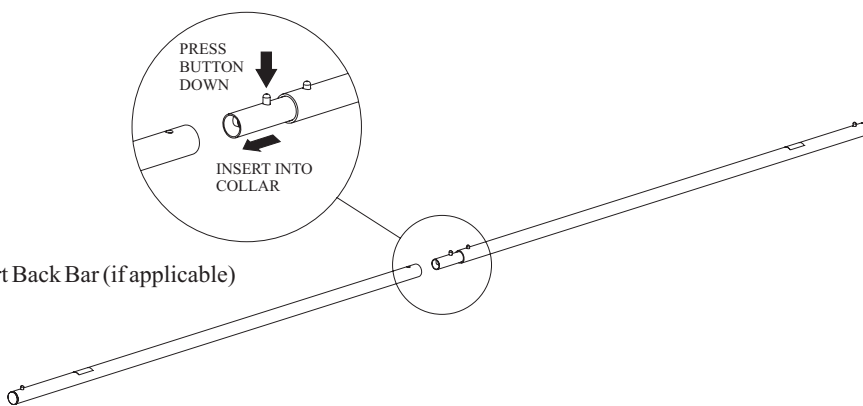

Insert Back Bar into Side Frame Collar

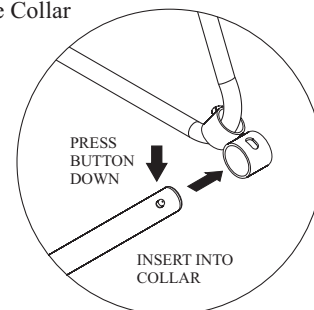

#### **Folding The Goal**

To fold the goal press down on the sideframe near the wheel with your foot and fold until the side frame tube locks in place. This must be done by 2 people.

#### **Operating the Wheel**

Lift the upright and flip the wheel into position.

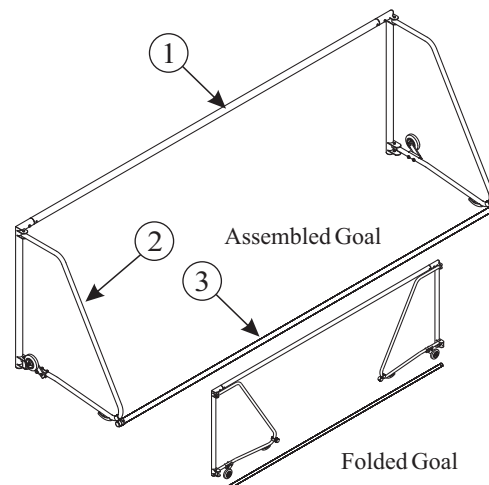
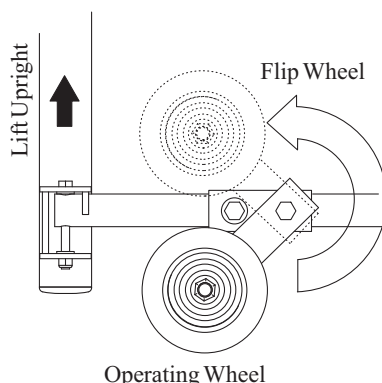
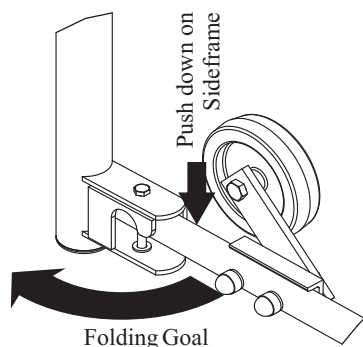

## GENERAL OPERATION & MAINTENANCE RECOMMENDATIONS FOR SPORTS GROUND EQUIPMENT



It is the responsibility of the facility operator to provide equipment that is fit for purpose and maintained to the required standard.

Operators also have a responsibility to staff under the Health & Safety at Work Act to ensure that staff are properly trained to carry out the required tasks for which they are employed. It is the facility providers who could find themselves liable in the case of any accidents where staff are found not to be competent.

### Assembly & Dismantling

- 1) When erecting equipment always use the instructions and recommendations provided by the manufacturer.
- 2) We remind you that the appropriate personal protective equipment (PPE) must be worn at all times. e.g. Hard hat, steel toe-cap boots, gloves etc.
- 3) When tall and/or heavy equipment is being erected it is recommended that scaffolding and/or heavy lifting equipment is used. A risk assessment should be carried out if necessary.
- 4) The correct tools for the job must be used at all times.
- 5) Assembly must be carried out by a sufficient number of competent persons.

### Checking Equipment

Equipment should be checked on a regular basis. This requires positive action, and the information gathered must be recorded and acted upon immediately should any faults be found.

- 1) Check all equipment a minimum of once every week - but always before any game or training activity.
- 2) Carry out a thorough visual check of the whole goal.  
Check that all fixings are secure and there are no loose or missing nuts, bolts, pins or other fixings.
- 3) If nuts, bolts, pins or other fixings are loose or missing it is not possible to assemble the equipment correctly. It is therefore vital that missing parts are purchased from the manufacturer to ensure compatibility.
- 4) If parts of the goal are bent or other damage is present there may be more damage internally which is not visible and could result in the goal collapsing or tipping. The goal should be taken out of action and removed from site.
- 5) Check that all pivot points are in good condition and lubricated with grease.
- 6) Any chips or scratches must be treated to prevent corrosion occurring at these points.
- 7) Check all anchoring attachments and anchoring points.
- 8) Should weight-type anchors be used, check there are the correct number for the size of the goal.
- 9) If you find a fault - you must record the fault and not continue to use the goal. It must be correctly repaired or replaced with new equipment.
- 10) Do not modify goals by welding or by substituting with incorrect parts. If any part is missing or broken, obtain a replacement from the original manufacturer.
- 11) Wheel mechanisms should be complete and in full working order.
- 12) Inflatable tyres must be checked for punctures and be inflated to no more than maximum pressure marked on tyre.
- 13) Cellular or solid type wheels are the preferred option as little maintenance is required.

### Checking Netting

- 1) Check for missing or broken net fixings as these may allow a ball to pass between the edge of the net and goal frame, resulting in confusion over whether or not a goal has been scored.
- 2) The size of the mesh of the net has been chosen to reduce the risk of injury caused by entrapment. If there are broken cords the holes become larger than intended and require repair or replacement.
- 3) Any broken cord in the nets may be able to be repaired using the same cord used to manufacture the net.
- 4) Nets must be stored out of direct sunlight and away from rodents.

***The Code Of Practice provided by BS 8461 gives guidance as to the type of check that should be carried out on football goals and how often they should be checked. Although this is football specific it is widely considered best practice for all sports.***

### Storage

- 1) Our recommendations regarding anchoring must still be adhered to when freestanding products are stored assembled.
- 2) If equipment has folding back supports it is recommended that the posts are stored flat on the ground. If they are required to be stored vertically, e.g. leant against a fence, they must be attached in such a way as to prevent them falling over.
- 3) When dismantled, parts must be stored safely & securely in order to prevent accidents in the storage area.

### Moving

- 1) Great care must be taken in moving the product whilst it is still assembled.
- 2) If no transportation wheels are provided, equipment must be lifted by a sufficient number of competent persons as stated in the assembly instructions to prevent injury, or damage to the product.
- 3) Equipment should never be dragged across the ground. Moving equipment in this way is likely to cause damage to both the product and the surface, whether natural or synthetic. Equipment must be lifted clear of the ground when it is being moved.
- 4) If additional weights are fitted to the goal, they must be removed first before attempting to move the goal. Once the goal is in position, carry the weights to the goal and re-attach.
- 5) Where goals with specific folding mechanisms are used, care must be taken to fold in accordance with both the instructions and labels. Damage can often occur when mechanisms are not released in the correct manner. Always refer to labels and instructions.
- 6) Fence folding style goals, with socketed support posts, are designed to be manoeuvred simultaneously by two competent persons. Care must be taken whilst moving the goal to ensure the net does not become entangled.
- 7) Goals fitted with wheels should be moved by using 4 competent persons in each corner of the frame and in the correct manner as stated in the assembly instructions.
- 8) In the case of integrally weighted goals, 4 competent persons must be used as per standard wheeled goals, it is important to check that the flip up wheel is locked in place before attempting to move the goal.

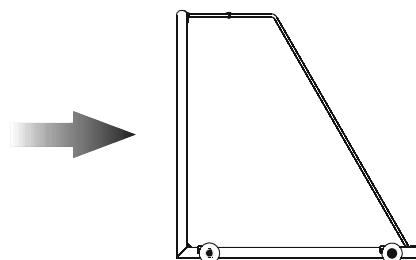

### Keeping Records

- 1) The safety of equipment is the responsibility both of the facility providers (who should provide safe goals, installed and maintained in a safe condition) and of the users (who should only use the equipment for its intended purpose).
- 2) Facility providers should be aware of operation and maintenance guidelines and keep records of all checks, installations and maintenance carried out.

Example 1 - Goal Record Sheet

Example 2 - Goal Inspection Sheet

#### GOAL RECORD SHEET



Goal Reference	Pitch 3 North End			
Date	Type of check	Findings	Action taken	Checked By
10th Dec	Weekly	Scratched Paint work on left hand upright	Painted over required area - Used Harrod UK White touch up paint	Harry Pitts
18th Dec	Weekly	All ok	None	Harry Pitts
2nd Jan 06	Full	Goal Passed Strength & Stability Test - No other problems	Full Goal Post Risk Assessment undertaken	Harry Pitts
10th Jan 06	Weekly	Goal Net has holes and broken meshes, some net hooks also missing	Purchased new net and clips and fitted to goal	Harry Pitts

Harrod UK Ltd, Pinbush Road, Lowestoft, Suffolk, NR33 7NL, England Tel: 01502 583515 Fax: 01502 582456 Email: sales@harrod.uk.com www.harrod.uk.com

#### GOAL INSPECTION SHEET



Site	Walmer Road		
Goal Reference	Pitch 3 North End	Type of Goal	Socketed Aluminium
Size of goal	7.32m x 2.44m	Stability Test Pass	Yes / No
Strength Test	Notes:	Start Height	mm
		Finish Height	mm
		Deflection Test	mm
		(more than 10mm is a fail)	Pass / Fail
Supplier or Manufacturer	Harrod UK Ltd	Date of manufacture	Feb 2005
Inspected By	Harry Pitts	Date of inspection	10th Jan 2006
Findings	Goal Net has holes and broken meshes, some net hooks also missing		
Action Taken	Purchased new net and clips and fitted to goal		
Contact details for spares and repairs	Harrod UK Ltd, Pinbush Road, Lowestoft, Suffolk, NR33 7NL Tel: 01502 583515, Fax: 01502 582456, Email: sales@harrod.uk.com		

### GUIDELINES FOR SPECIFIC SPORTS

#### Hockey

- 1) We strongly recommend that wheels are used to transport hockey goals, otherwise the goals should only be lifted with a minimum of four competent persons.
- 2) Only devices specified by the manufacturer must be used to manoeuvre goals.
- 3) Hockey Goals with rear fitted wheels must be tipped onto the wheels using four competent persons. There should be one person in each corner of the goal. The top rear support bars and side frames are integral parts of the goal for supporting the netting and are not to be used as the principle method for tipping the goal.
- 4) When using front flip-over type wheels, the lifting handles fitted to the goal are to be used when flipping the wheel into place. This requires two people per side (one to lift, one to flip).

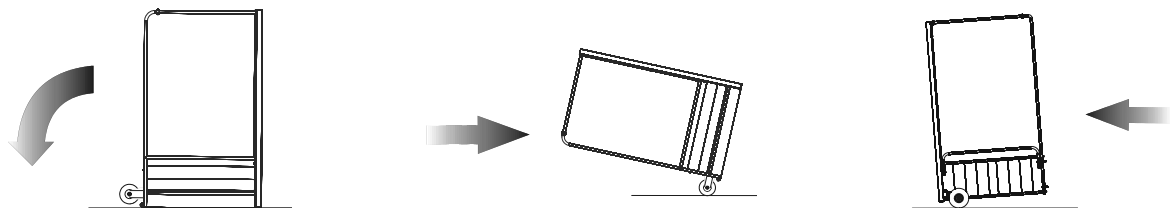

- 5) In the case of integrally weighted, 4 competent persons are required to move the goal. Standing directly behind the goal. Put one foot on the axle bar to stabilise the goal and at the same time pull the goal back together until the goal is in the position. Manoeuvre the goal into the desired location and carefully let the goal down, making sure that the goal is not dropped.
- 6.) Integrally weighted goals require a minimum pitch run off of 2 metres and must not be stored with the back of the goal against a surround fence or wall. To ensure the goal can be moved space must be available to allow the goal to be tipped up onto its roller.

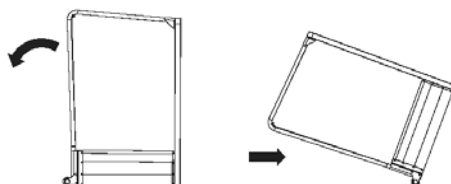

## Tennis

- 1) Freestanding Tennis Posts should only be moved by means of transporter trolleys, unless the posts have been completely dismantled.
- 2) A minimum of 2 transporter trolleys must be used per set of posts.
- 3) Posts should not be stored on trolleys at any time.
- 4) Only use trolleys that were specifically made for transporting tennis posts.  
Two competent persons are required to lift each end of posts onto the trolley. Use fixing bolts to secure posts on trolleys before attempting to move.
- 5) Care should be taken not to over tension the net as this can potentially cause each end of a freestanding tennis post to lift and render the posts unstable.
- 6) We recommend the net winder handle be removed if the posts are left unsupervised.

## Netball

- 1) Freestanding posts must be laid down and stored in a secure covered location when not in use.
- 2) Freestanding posts must only be wheeled in a pushing motion from the top of the post.

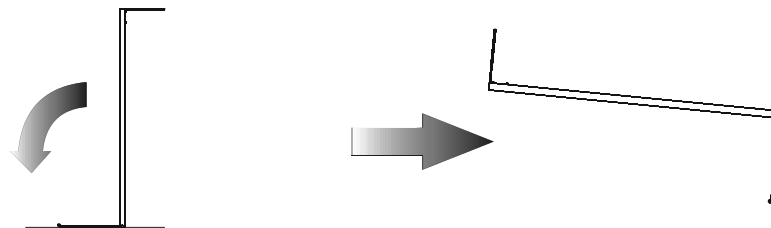

## Shelters

- 1) Aluminium team shelters are designed to be permanently fixed to an appropriate prepared surface.
- 2) Correct amount of fixings should be used dependent on the size of the shelter.
- 3) When moving shelters the correct number of competent persons are required (please refer to the Manual Handling guidelines).
- 4) Shelters should never be left unsecured.

## Pitch Dividers

- 1) Pitch Divider Systems are designed to have wire as a permanent fixture and this should not be removed on a regular basis.
- 2) If wire is required to be taken down, release the pressure on the wire, detach from anchor post, coil and tie it off, then store the wire in pouch with the netting.
- 3) Pitch divider netting is retractable and should be stored in a storage pouch.
- 4) The netting must be retracted using a 'pull and draw' system. This is achieved by standing at the storage end of the system and by slowly pulling the net inwards until all the netting has been gathered. Do not walk with it from one end to another as this will cause the netting to become entangled and put excess stress on the clips used to suspend the netting.

## Anchorage

**Background :** In the UK, standards for Goal posts and nets for a variety of sports are set by The Comité de Européan Normalisation which has been in existence since 1989. Other standards have also been set in more recent times by the BSI, specifically for junior, mini, small-sided football and Futsal. Harrod UK have been representatives on the CEN Committee since 1989, the F.A. Guidelines Committee in 2003 and the BS 8462/8461 Committee in 2005.

**Purpose of CEN:** To normalise and raise standards for goal posts throughout the European Community. A committee whose aim is to ensure all equipment is manufactured to the highest standard, and to create awareness of the highest level of responsibility bestowed upon the authorities responsible for the equipment and its use.

**Implications :** Providers of sports equipment have a responsibility to supply equipment that is fit for purpose and above all safe to use at all times. Equipment that conforms to BSEN and BS standards has to be independently tested for both 'strength' and 'stability' by a registered testing house and manufacturers are obliged to produce copies of these certificates on demand.



☒ Senior Integrally Weighted Goal

At Harrod UK we have long since identified the need for 'bullet proof' goals and have developed a unique range of integrally-weighted goals. These goals are safe to use at all times, require no further anchorage and have been widely acknowledged at the SAPCA and Sports College Conferences as the safest metal goal available in the market place today. The continuing F.A. campaign highlights the responsibilities of pitch providers to ensure they only use goals that conform, and we cannot emphasise strongly enough that end users have the ultimate accountability in this respect.

### Official Goal Sizes

Type Of Goal	Internal Sizes (mm)	Appropriate Specification	Strength Test	Stability Test	Amount Of *ANC-005 Required
Senior (Full Size)	7320 x 2440	BS EN 748:2004	180 kg	110 kg	Qty 6 (per goal)
Youth Football	6440 x 2130	BS 8462:2005	180 kg	110 kg	Qty 6 (per goal)
Mini Soccer	3660 x 1830	BS 8462:2005	80 kg	70 kg	Qty 6 (per goal)
Small Sided	4880 x 1830	BS 8462:2005	80 kg	70 kg	Qty 6 (per goal)
Small Sided (Gross Mass of 18kg or more)	4880 x 1220 3660 x 1220 2440 x 1220	BS 8462:2005	80 kg	70 kg	Qty 4 (per goal)
Futsal	3000 x 2000 x 2000	BS 8462:2005	180 kg	110 kg	Qty 6 (per goal)
Hockey	3660 x 2130	BS EN 750	180 kg	110 kg	Qty 10 (per goal)

\*ANC-005 This is a counterbalance type weight anchor used for anchoring freestanding goal posts

Anchorage: To achieve the above stability test, goals (in the case of socketed type) must be installed with the correct amount of concrete around the socket, or in the case of freestanding goals, be anchored in the correct manner. Full details of Harrod UK anchorage systems are available at [www.harrod.uk.com](http://www.harrod.uk.com)